



Introductory design project in wood

Developed and written by Merrick Russell

Folio by:

Class:

Teacher:

Contents	Introduction	2
	Portfolio task list and marks	2
	Information sheets	3
	Memphis	3
	Homework questions	5
	Wood	8
	Equipment	11
	Standard operating procedures	15
	Working with wood	17
	Practice exercise	18
	Design Brief	19
	Concept sketching	21
	Concept sketches	22
	Concept development	23
	Marking out plan	23
	Making the Pencase	24
	Accurate perspective drawing	26
	Evaluation	27
	Class test	28

Introduction

In this project you will design, make, evaluate and present a wooden pen case based on the principles of the Memphis design style. It will be an introduction to the design process as well as working with tools.

Students learn about:

- Design principles from the Memphis group
- The design process
- Wood and wood products
- Perspective drawing
- Safe working practices

Students learn to:

- Generate concept sketches;
- Present design ideas graphically
- Apply a design process
- Work with plywood and radiata pine
- Use the reciprocating saw, coping saw, tenon saw, pedestal drill, hand drill, cordless drill,
- Use Corel Draw to generate a top view and marking out plan
- Draw in perspective and present design ideas graphically

Portfolio task list and marks

	Description	Mark	Max
1	Complete the 12 questions related to the information sections.		45
3	Class test on Memphis design, working with wood, and equipment		15
4	Concept sketches		10
5	Practice working with wood exercise		5
6	Design development and computer generated top view of chosen design		10
7	Quality of design. Does it fulfil the design brief? Is there user delight?		25
8	Quality of product. Is it well made?		25
9	Complete the general evaluation questions.		10
10	Accurate perspective drawing.		10
	Total		145

Memphis

The style that defined the 80's

Whenever a design style becomes popular we should sit up and take note, because its success has something to say about ourselves and the times we live in.

In the early 80's a new 'look' took hold that changed the domestic landscape for a decade. It was suddenly OK to have furniture that was less serious and more playful. Out of nowhere pink and grey were somehow decided to be a cool colour combination, and small triangles and squiggles started invading all kinds of surfaces from bench-tops to garments and album covers. It was easy to see where Memphis had left its mark.

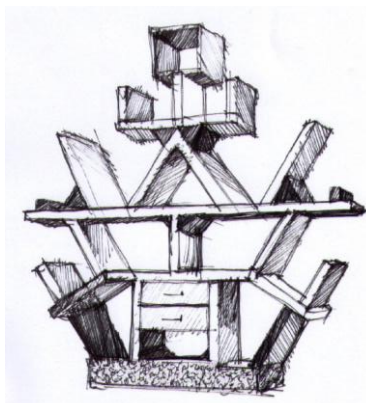

Ettore Sottsass, Carlton bookcase 1980

It is helpful that Memphis was so well defined in **stylistic terms**, but it doesn't make it any easier to understand. There are in fact two stories to tell when it comes to the Memphis design style: a description of the defining features (what it looked like); and understanding why it was successful, especially given just how quirky it was.

The Memphis design style was characterised by strong colours, **incongruous** colour combinations and a cartoonistic play with forms. It wasn't about glamour, sophistication or harsh **minimalism** – it was about fun. Stripes, squiggles, and boldness were the vocabulary of a new **design language** and these were applied to objects of everyday use like clocks, chairs, lamps. Unlikely colour use gave the objects a kind of **manufactured**

fakeness, as though everything that the object had to say about itself was skin deep, only on the surface. It was a kind of industrial **confection**. There was nothing natural about this celebration of the manufactured. Shiny plasticness **usurped** any reference to nature. Memphis was primarily a design style fixated on ornamentation and with getting a reaction from the user. It may be easy to dismiss Memphis as faddish but its success speaks of a **resonance** with wider cultural values. It had a message and people liked it.

Now there is nothing completely new about bold colours and a fixation on small triangles and squiggles, so this makes the following question even more **pertinent**: why was this style popular when it was? The popularity of a design style comes from more than just what someone decided looks good. The underlying ideas need **traction** across a community. And here is a key concept: design styles are an expression of ideas.



So what was the message of Memphis? To understand Memphis we need to look at what major design style **preceded** it, and that was Modernism. Modernism in design started at the Bauhaus (1931), a design school fascinated by the machine and with a desire to bring a kind of scientific rigour to the world of aesthetics. The result was a rejection of ornamentation and a **proliferation** of plain surfaces. These ideas were seductive,

because they spoke of the future – a bright shining new future determined by a scientific, rational thinking.

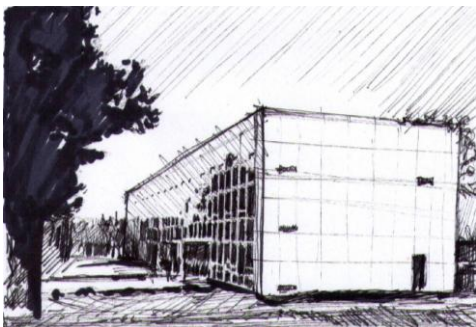

At its height Modernism in design stood for a rational, anti-ornament approach.

When transferred into architecture this new design thinking struck gold because architects could take on the role of social engineers, an elevated status. This 'functionalist' style in the end was dehumanising and by 1974 there was a wholesale rejection of its **tenets**. It seemed that it was only the architects who ever liked it. Over the next few years as the failure of Modernism brought a new question – what would replace it?

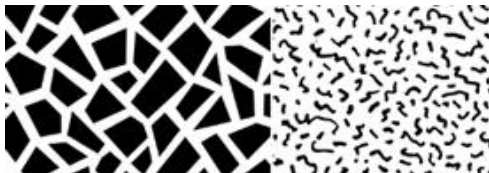

Plastic laminate was seen as a new design opportunity, especially for bright, solid colours and new patterns.

This is where Memphis comes in. At its heart it was a reaction against the harsh **austerity** of Modernism. And all it had to do to succeed was to be the opposite of Modernism. Where Modernism was simple and plain, Memphis celebrated ornamentation; where Modernism rejected historical reference, Memphis welcomed it back; where Modernism was an imposed design style, Memphis expected the users to interact; where Modernism had lofty aims of improving our consciousness, Memphis just wanted to have fun. The designed world was now accessible to everyone not just the design elite. It may

have represented a dumbing down of design, but at least people could enjoy it and this was enough. In fact isn't this all design should set out to achieve?

As with all design styles there are people behind it. Memphis was actually a group of Italian designers led by Ettore Sottsass from 1981 – 1985. On the back of their first exhibition of furniture pieces in 1981 the word Memphis was used for more than just this group – they had spawned a new style. The name *Memphis* is deliberately confusing, a bit like an **enigmatic** rock song that becomes popular, but no one really knows what it means. This is very Post Modern because there is a **plurality** of possibilities. Certainty of meaning was no longer an aim as it was in Modernism and the name *Memphis* plays to this.



Ettore Sottsass

There was no Memphis **manifesto**, none of the original members of the Memphis group was really that interested in explaining what they were trying to achieve except to reinvigorate design. Memphis didn't set out to 'change the world', but it actually did. Memphis changed the relationship between the designer and those who used their designs. It reasserted that the users of design are more important than the creators. Design was about the people who use it.

In 1985 Sottsass disbanded the Memphis design group. It was only ever meant to be a **fad**, but it had done its job, to reinvigorate design.

Homework questions:

1. Write down the meanings of the following words: (12 marks)

resonance

To vibrate at the same frequency as something else. In this context: a profound agreement displaying shared values.

incongruous

Ideas that don't belong together.

minimalism

Removing all unnecessary elements from design particularly ornamentation

confection

A completely made up item usually from sugar.

usurp

To undermine or take over.

traction

Grip. In this context: when ideas take hold and people notice them and agree with them.

proliferation

An abundance but also with a sense of growth.

tenet

A fundamental idea that drives motivation. A belief.

enigmatic

Mysterious and somehow secretive without necessarily intending to be.

plurality

A range of ideas that may even compete with each other.

manifesto

A set of ideas and beliefs that are clearly stated. A statement of how these ideas will change the status quo.

2. Explain the meanings behind these concepts: (6 marks)

domestic landscape

The full set of furniture and fittings we surround ourselves with around the home.

design language

The way designers express ideas: through designed objects. This agrees with the notion that objects can have meaning.

3. Name five of the members of the Memphis design group. (research required) (1mark)

Mellini, Sottsass, Bedin, Branzi, Cibic, de Lucchi, Pasquier, Graves, Hollein, Isozaki, Kuromata, Thun, Mariscal, Zanini, Radice

4. Draw a picture of a Memphis design that refers to something historical or tribal. (4 marks)



Name of design: _____

Name of designer: _____

Year: _____

5. Draw a picture of a Memphis design that looks a bit like an animal. This is called zoomorphism. (4 marks)



Name of design: _____

Name of designer: _____

Year: _____

6. What were some of the problems with Modernism as a design style, especially as seen in architecture? (3 marks)

Set meanings meant that the user didn't interact with the designs.
Minimalism was very serious and didn't engage the senses.
It was a style for architects not users.

7. In your own words explain why Memphis was popular. (3 marks)

It engaged with the user's need to look for meaning in objects
It was fun
It referred to other design styles.

- 8 Why did Sottsass choose the name *Memphis* for this new design group? (research required)
(2 marks)

He heard a song on the radio that mentioned the word Memphis and that was good enough.
There was no real reason for this name which in itself fits in with the non serious and
enigmatic nature of the design style

Watch <http://www.youtube.com/watch?v=LSGutSMWzCU&feature=related>

- 9 Why did Ettore Sottsass give up designing typewriters? (1 mark)

He became bored

- 10 Where did Ettore Sottsass get his inspiration for bright colours? (1 mark)

On a trip to India

- 11 How is Memphis like eating cake? (2 marks)

If you have too much you will get sick

Wood information sheet

There are two basic forms of wood, **softwood** and **hardwood**.

Softwoods

All softwoods are evergreen. This means they do not shed their leaves during cooler months. They are cone bearing trees and are often called *coniferous* or *conifers*. Softwood prefers the cooler regions of the world, Canada, Scandinavia, and Northern Russia. They grow very quickly reaching full maturity is about twenty years. In Australia softwood trees are grown commercially and are commonly seen in plantations in areas surrounding Canberra.

Hardwoods

Hardwoods are generally denser and therefore *harder* than softwoods. Most hardwood trees shed their leaves during the winter months but tropical hardwood trees such as those found in Australia keep their leaves, and as a consequence grow much faster. It is not unusual for an average hardwood tree to take up to one hundred years to grow to full size and because of this they are very expensive to purchase as timber.

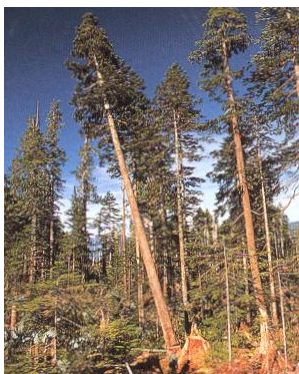

Softwood trees



Hardwood forests

Softwood varieties

Radiata Pine – Australia
 Parana Pine – South America
 Spruce (Whitewood) – North America
 Red Deal (Scots Pine) Russia
 Red Cedar - Canada

Hardwood varieties

Beech – Europe
 Japanese oak – Japan
 Mahogany – South America
 Meranti –S.E.Asia
 Teak –India
 Brush box – Australia
 Obeche – West Africa

Conversion and Seasoning – Preparing for use

Once trees are cut down, or felled, they are processed into planks and boards. This process is known as *conversion*. The logs are cut using large circular saws into a variety of patterns that determine the quality of the finished piece of timber. Even after the timber has been converted it contains a large amount of moisture, which has to be removed before becoming useful to work with. This process is known as *seasoning*. The water content is brought down to 10 % either by drying the wood naturally over a period of several years, or using a special kiln which takes a few days. The important thing is to reduce the moisture in a controlled way so that the wood cells don't collapse.

Kiln Drying – Loading and the process

Conversion Techniques

Load the kiln

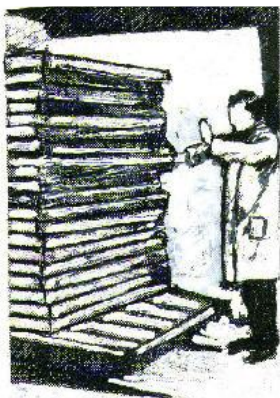

Inside the kiln

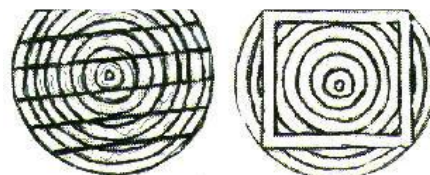
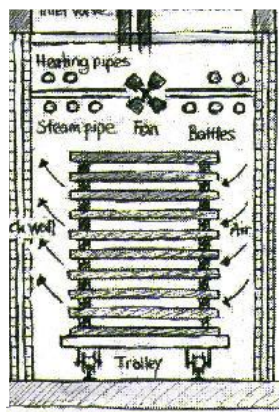

Slab cutting

Slab sawn

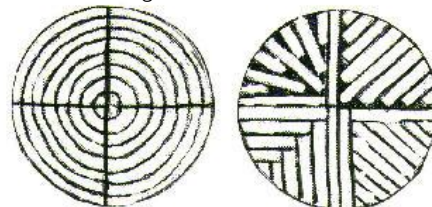

Radial methods

Manufactured Boards

More and more we are using timber boards that are manufactured. This is much more sustainable than using solid wood.

Manufactured boards are made from wood products. The wood is cut up in a variety of ways and then stuck back together with very strong adhesives. The main advantage of these boards is that they can be made into large flat surfaces and they rarely twist or warp if stored properly. Three common manufactured boards are:

MDF – Medium Density Fibreboard is an economical board that is much denser and heavier than other boards. It has smooth faces and is easy to work with. The general size of a MDF board is 2400 x 1200mm. It is made up of fine particles usually glued together with a formaldehyde glue which is a threat to health if the dust particles are not collected properly.

Plywood is a laminated material. This means that thin layers of wood are stuck together with their grains at 90 degrees to each other. As the strength of natural timber is in the grain this board is very strong.

Particle board is a much lighter board made from small flakes and chips stuck together with very strong adhesive. Particle board is often covered with a thin layer of plastic and used to make kitchen cabinets and cheap furniture. If you leave particle board outside the glue dissolves after about a year and you are left with a pile of wood chips.

Homework

12 Find pictures of three designer items. One made from each of the following: (6 marks)

- Plywood
- Solid hardwood
- Particle board

Cut and paste picture of chosen design here	Material: Plywood
	Name of item:
	Designer:
	Why is this design interesting to you?

Cut and paste picture of chosen design here	Material: Solid hardwood
	Name of item:
	Designer:
	Why is this design interesting to you?

Cut and paste picture of chosen design here	Material: Particle board
	Name of item:
	Designer:
	Why is this design interesting to you?

Equipment

In this project you will become familiar with the following equipment:



RECIPROCATING SAW



DISC SANDING MACHINE



PHILIP'S HEAD SCREW DRIVER



HAMMER



SAFETY GLASSES



EAR MUFFS



DUST MASK



PVA GLUE



CORDLESS DRILL



HAND DRILL



HOLE SAW

APRON



DUST PAN & BRUSH



DRILL PRESS



DRILL BITS



HOLE SAW CHUCK



TENON SAW



FORSTNER BIT

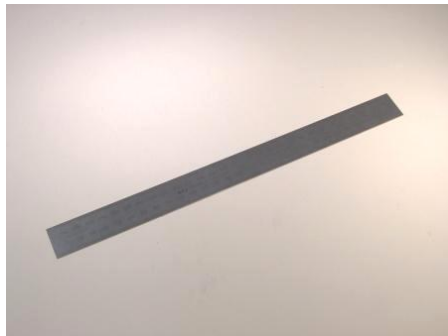

STEEL RULER



COPING SAW

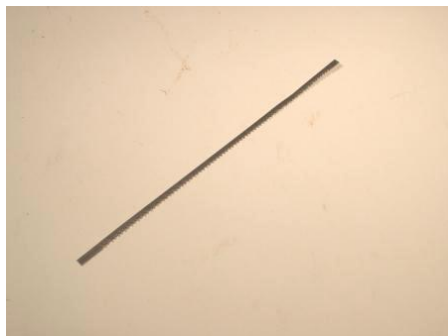

COPING SAW BLADE



TRY SQUARE



SANDING BLOCK

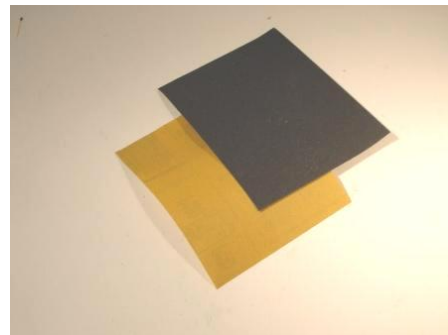

SANDING PAPER



BAR CLAMP



BENCH VICE



FLAT SMOOTH FILE



ROUND FILE



SQUARE FILE



NEEDLE FILE

Become familiar with the names and the uses for this equipment. You will need to know this for the making stage of the design process – and also for the class test.

Standard Operating Procedures

As with all workshop equipment there are Standard Operating Procedures that you will be expected to follow.

Pedestal Drill

Conditions For Use

- First-time users must ask teacher to demonstrate operation of the equipment.
- Use only for drilling wood, plastics and metal.

Hazards

- Drill can break and cause injury to hands.
- Eye injury from flying chips.
- Work piece can become a projectile.

Operation

- Wear Apron, Safety Glasses.
- Use vice or clamp to hold work piece.
- Ensure drill bit is centred and secured in chuck.
- Adjust base plate height as required. Do not build up table.
- Position guard and slowly lower to drill hole.
- Switch off power when finished.
- Make sure spindle has stopped before removing work or waste.

Disc Sander

Conditions For Use

- First-time users must ask a teacher to demonstrate operation of the equipment.

Hazards

- Work piece can jam in between disc and work table if held at angle.
- Any contact with the moving disc will cause grazing.
- If the wrong side of the disc is used the work piece may fly up.

Operation

- Wear Apron, Safety Glasses and Ear Protection.
- Use only right half of disc. Use guide as required.
- Engage dust extraction.
- Place work piece flat on the table at all times.
- One operator only in front of the safety line.
- Operator is not to talk with anyone.
- No one is to talk with the operator (except supervisor)
- No piece smaller than 50mm is to be used.
- Thickness of work-piece is to be between 3mm and 100mm.
- When finished switch off sander and disengage dust extraction.

Portable Power Tools

Conditions For Use

First-time users must ask a teacher to demonstrate operation of the equipment.

Hazards

- Risk of electric shock.
- Contact with sharp or abrasive moving or rotating parts can cause cuts.
- Trailing cables can present a tripping hazard.
- Portable power tools can present a noise hazard.
- Dust can cause injury to lungs.

Operation

- Wear Apron, Safety Glasses, ear protection and Dust Mask as required.
- Check power lead and plug. Do not use if damaged.
- Make sure the ON/OFF switch on the machine is in the OFF position. Turn on power at the outlet socket. Turn on at machine when ready.
- Never carry a tool by the cord.
- Never yank the cord to disconnect it from the power supply.
- Keep cords away from heat, oil, and sharp edges (including the cutting surface of a power saw or drill).
- Work should be held in a vice or clamped, allowing both hands to grip the power tool.
- Hold the tool securely especially the router which can grab or kick.
- Drilling should be done at a constant angle to the work.

Reciprocating Saw

Conditions For Use

- First-time users must ask a teacher to demonstrate operation of the equipment.

Hazards

- Saw blade can break and cause injury to hands.
- Sawdust may be thrown in eyes.

Operation

- Wear Apron, Safety Glasses.
- Set foot to just above thickness of material. The foot must be set close to the blade.
- Check saw blade for proper tension.
- Guard must be raised under the table
- Adjust saw speed as required.
- If saw blade breaks, replace blade and tension properly; if unsure how to do this ask for help.
- When finished switch off saw and light.

Working with wood

Using the information from the demonstration complete the following table in point form.

	Equipment used	Remember to....	Safety
1. Marking out	Pencil Steel rule Try square	Use the edge of the material where possible Mark out circles with a cross at the centre Mark out the waste side of the line with a squiggle	n/a
2. Cutting	Reciprocating saw Coping saw Tenon saw	Set foot to the right height Ensure blade is tight Clamp work Cut on the waste side of the line	Keep hands clear of moving blade
3. Shaping (Disc sander)	Disc sander	Move work side to side as you push it in so that an even amount of material is removed. Turn it off when finished	Use the down side of the disc only Hearing protection Extraction Know how to turn it off quickly Keep fingers away from disc Put work flat on table No piece thinner than 3mm
4. Drilling	Hand drill Pedestal drill (drill press)	Choose the right drill bit or hole saw Learn how to set it correctly in the chuck (you may need to look into the chuck to see what is going on) Clamp the work well making sure that there is a piece of scrap wood under the work.	Lower chuck guard Keep hands away from moving parts Clamp work well Drill slowly with a hole saw or forstener bit.
5. Joining	PVA glue Nails Hammer	Mark out where the nails are to go Use a very small amount of glue (think wasabi not tomato sauce)	Small nails can be held with pliers if you are likely to hit fingers with hammer.
6. Finishing (painting)	Water based acrylic paint Brushes	One colour per brush Only use the tip Before putting the brush in the paint start using it – there may be enough paint on it already One colour per piece Use black for the base and the sides. Don't pain the top rim of the sides or the undersides of lid and cover.	Paint in a well ventilated area

Working with wood

Practice exercise (5 marks)

Using your knowledge of the tools below make the shape shown below from 3mm Plywood.

Marking out:

pencil, try square, steel rule

Drilling:

hand drill, pedestal drill, clamp, drill bit

Cutting:

reciprocating saw, coping saw, vise.

Shaping:

disc sander, file.

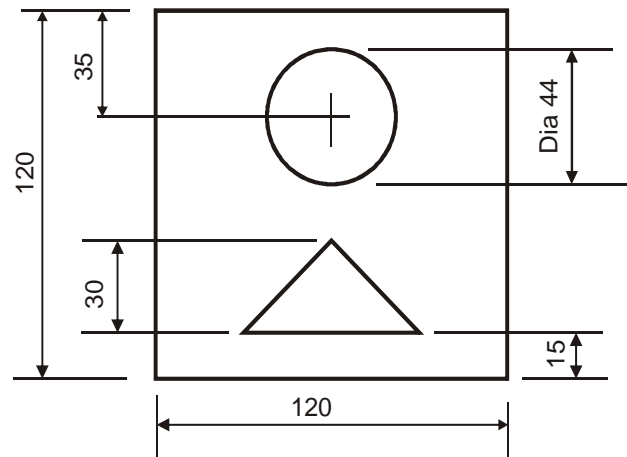

Note that to make the triangular hole:

- 13 Drill a hole and feed a coping saw or reciprocating saw blade through it
- 14 Re-attache the blade
- 15 Cut as close to the line on the waste side as possible
- 16 Cut into each corner twice. You will not be able to turn inside the corner.
- 17 Remove the blade and file with a half round file down to the line.

Design Brief

You have studied the main ideas behind the Memphis design style and how it represented a departure from Modernism. In this design brief you will create a piece that captures this moment in design history.

Design and make a pencil case using radiata pine and plywood. Keep your shapes simple and colours are to be primary and tertiary colours. (red, blue, yellow, purple, orange, green). The lid is to be rotated into place around a securing screw. The lid will be held in place by sliding under part of a cover piece.

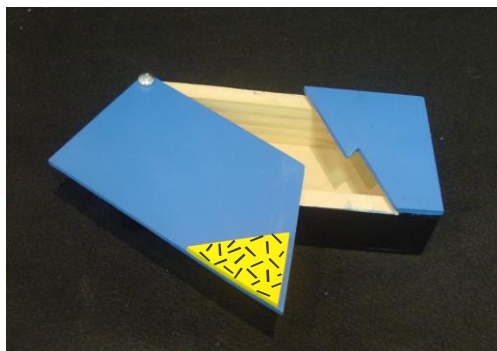

Parameters:

- You will be given one piece of pine 600mm long with a cross section of 12mm x 35mm, and three pieces of ply 200mm x 100mm.
- Your final product will be approximately 190mm x 90mm x 18mm
- Use one screw only (you may need to move this from centre for your design). The screw is long enough to only go through one width of plywood.
- Do not modify the shape of lid or spacer.
- Modify the shape of the cover piece, but it must remain bigger than the spacer.
- Include an add-on of your design. Use primary and tertiary colours only
- Use only one colour per piece.
- The side pieces and base are to be painted black.
- Make sure your lid will swing open before you start cutting out your pieces.
- Apply a pattern to one surface only. This is done with black or white vinyl cut into small shapes the choice of patterns is: small squiggles, stripes, small lines or small triangles.

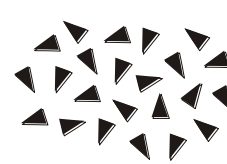
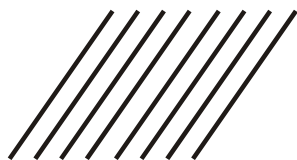
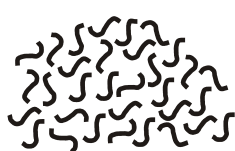

Submission:

- 1 Concept sketches
- 2 Orthogonal drawing on computer
- 3 A finished product
- 4 An accurate perspective drawing
- 5 An evaluation

Indicate which parts are plywood and which are radiata pine.

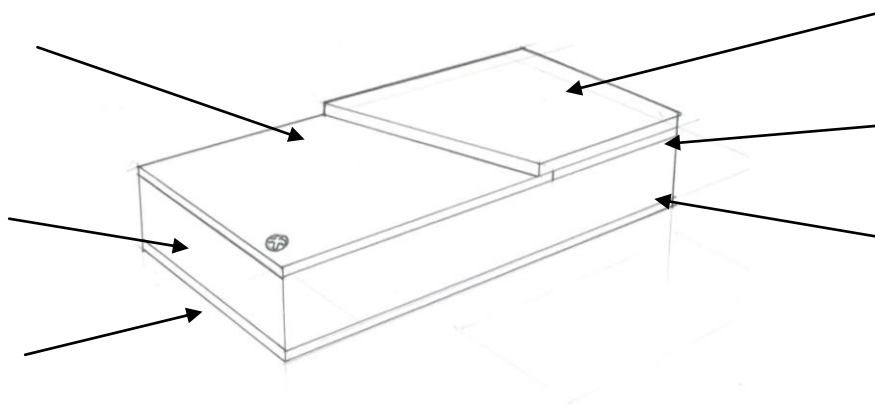

Why are the spacer and lid cut at an angle?

So that when the lid rotates back into place it 'locks'

What is the job of the cover?

To provide enough friction with the lid so that it slides under it and stays in place

Does it matter where the screw goes?

Yes. It needs to allow the lid to rotate open. The location needs to be decided according to the shape of the lid and spacer.

If the lid does not slide under the cover what could be the problem?

The lid may be too thick and need to be sanded down at the area that needs to slide under the cover. Painting often makes the lid too thick. This should be considered before painting.

Here is an exploded view and an assembled view of the basic pen case.

Show which parts are glued and nailed together.

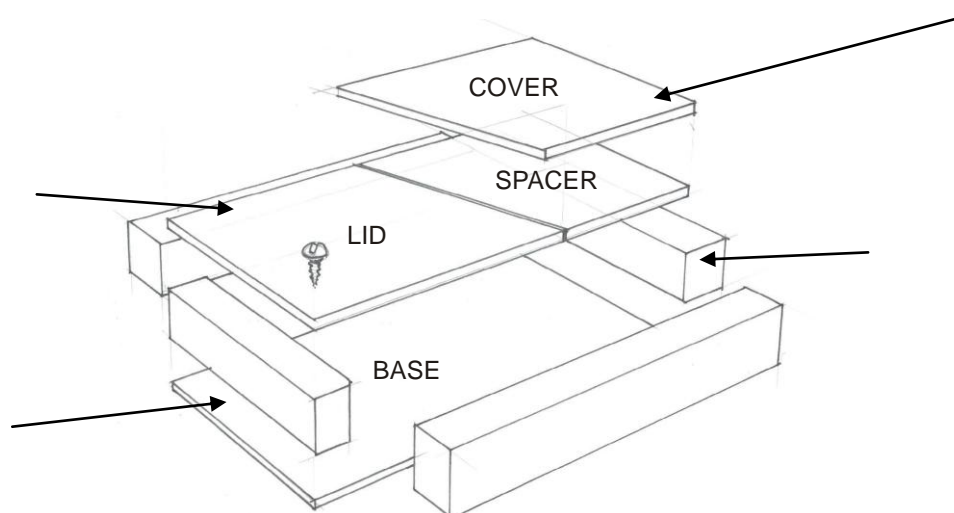

User delight

There is an excellent opportunity in this project to design an object that delights the user. This is an interactive object that requires the user to experiment to learn how it opens. The less obvious this is, the more interesting it will be.

Concept sketching technique

Early in the design process the name of the game is generating ideas. Your drawing will need to be quick, and a bit of mess is fine – it shows that you are thinking creatively. You will also have more ideas to choose from. A ‘what if...?’ kind of mind set is what you want to use. Be curious about variations of ideas and draw them. If you are drawing slowly then you’ll get stuck.

By drawing quickly and not being too concerned about mistakes, we are helping our brain think in a certain way. The act of drawing and seeing these ideas can actually stimulate us to have more ideas. It is very likely that the idea we choose to develop further would not have sprung from our mind without the activity of sketching and continual evaluation. Using fineliner (not pencil) follow the steps:

1. Construction lines

Light-weight lines that are drawn too long (and are not made up of multiple short lines). Keep them light by drawing faster (this will also help them to be straight). Most construction lines are in fact not the line you will end up with. If you draw a construction line that is not what you want then repeat that line until you get the one you want.



2. Firming lines

Now that you have constructed the shape go over all the correct lines a second time with fineliner, but drawing slowly to achieve a darker line. All the incorrect lines will be less noticeable. Firming lines are also drawn long and straight where possible.



3. Shading

Light-weight crosshatching. These lines are diagonal, but should not be parallel to any other line on the object. One of the vertical surfaces is chosen for shading (as well as any other vertical surface facing the same way). Shading lines start and finish just outside the shape you are shading.



4. Outline

With thicker fineliner draw a dark line around the perimeter of the object. Once again make these lines straight and too long. The dark outline cleans up any mess from construction, firming and shading.



5. Annotation

Show that you have solved important problems or are at least thinking about them by writing notes about materials and joins. These notes should not appear to be a part of the object and so they should be outside the object, be small, and if they refer to a particular part of the object then a wavy arrow is helpful.

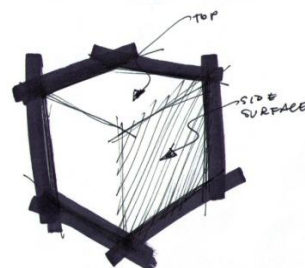

Concept sketches

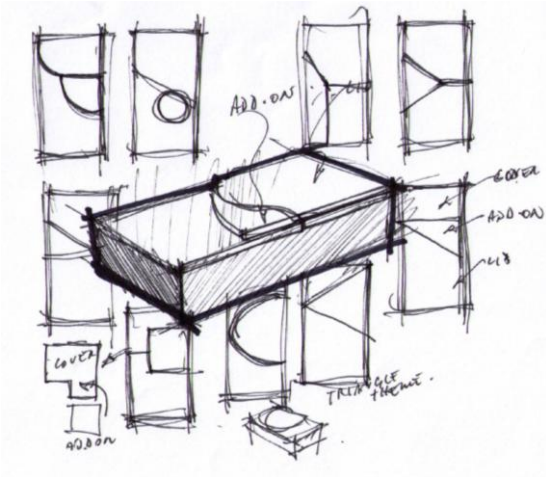

Example. Notice that:

- There are a range of views.
- There is a big 3D view of one in the middle.
- Overlapping is OK.
- Construction, firming, shading and annotation has been used.
- Fineliner has been used.
- 10 ideas have been generated.

In the space provided complete a set of concept sketches using the techniques shown.

Design development

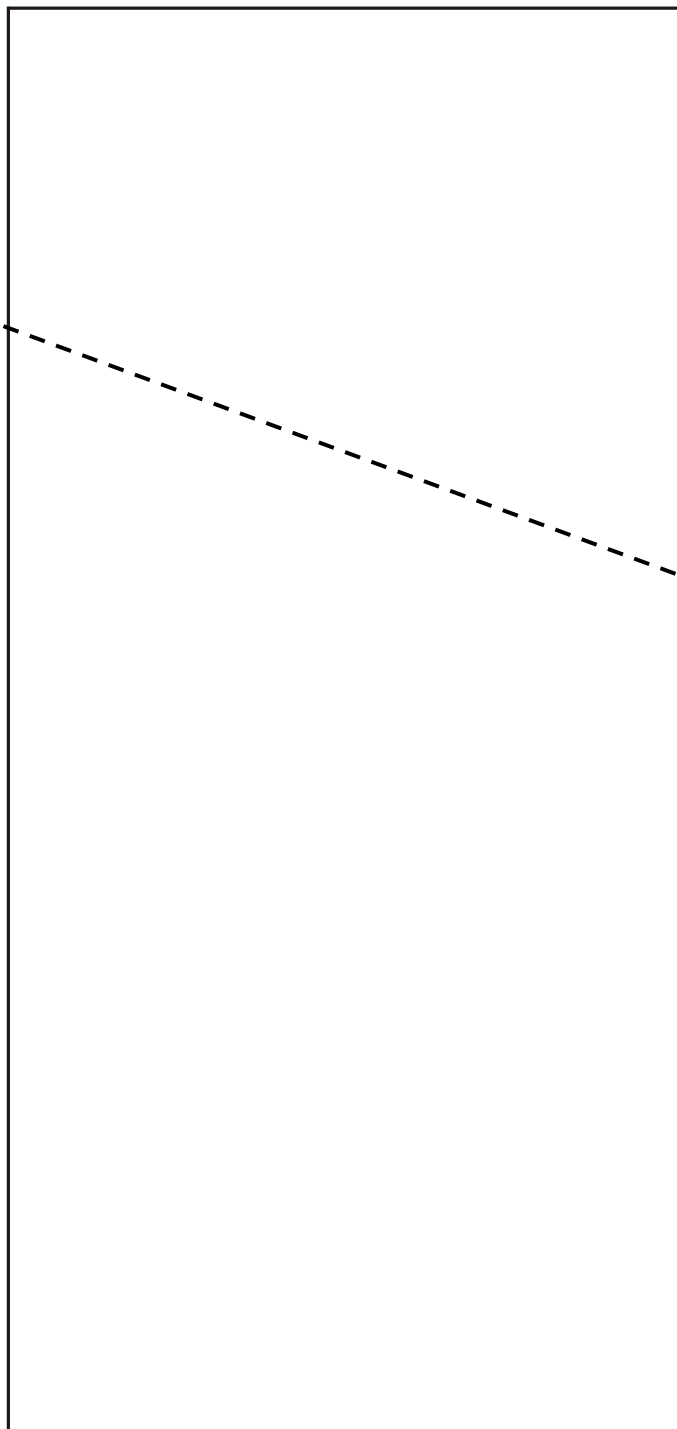

Here is the outline of top view of the Memphis pencil case drawn at scale 1:1.

Complete the top view by drawing the details of your chosen design.

- Use a ruler where you can.
- Indicate where the screw goes
- Indicate which is the lid, cover and add-on.
- The edge of the spacer (even though you won't see it) is shown with a hidden detail line: - - - - - Make sure the cover piece entirely covers the spacer.

Marking out plan

Using a program like Corel Draw or Illustrator draw your top view again at scale 1:1.

- Make sure all the parts (lid, spacer, add on and cover) are individual entities.
- Rotate the lid around where the screw will go to test that it will pen without interfering with the spacer.
- Separate them and fit them into two rectangles 200mm x 100mm
- Print this out. This is your marking out plan that you will use to mark out your shapes onto the wood.

Making the pen case

Use this as a reference when making your pencase

You will need:

- Your marking out plan
- 3 pieces of ply (200mm x 100mm)
- 1 length of pine (600mm)

What to do:

Marking out

- 1 Transfer the shapes from your marking out plan onto the wood.
- 2 Use the edge of the wood as much as possible. This minimises cutting.
- 3 Use a try square when you can.
- 4 Mark out the waste side of the line
- 5 Use a pencil, be accurate.

Cutting the sides

- 6 You will be given one long length of pine with a cross section of 12 x 35mm. This needs to be cut into four pieces (two short pieces and two long).
- 7 The short pieces must be no longer than 66mm and they must be exactly the same size. To achieve this mark out a line very near the end of the wood and then another 66mm away from the first line. Use a try square.
- 8 Leave 2-3mm waste and repeat.
- 9 Using a tenon saw make two cuts on the waste side of the line.
- 10 On the disc sander square up one side on each piece separately, and then put them both together with the good ends aligned and square up the two rough edges together. This will give you two pieces of the same length with good ends.
- 11 The two long sides are cut from the remaining pine in the same manner. They should both be 185mm long (it is not critical that they are *exactly* the same length).



Joining the sides to the base

- 12 Take one of the ply pieces to be your base. Trim it down to 185mm in length. Mark out a border in pencil 6mm in from every side.
- 13 Apply a smooth thin layer of PVA glue to each face that needs joining (including the ends of the short pieces).
- 14 Position the sides and on the base and turn the base over to show the border that you have drawn.
- 15 Hammer in small nails along the border line, two for the small sides and three for the long sides. Make sure the nails go in straight otherwise they will stick out the sides in which case you will need to get them out and re-nail them.
- 16 Don't keep hammering if the nail is bending. Remove it with pliers or pincers and start with a new nail.
- 17 Using a nail punch, hammer the nails in just below the surface.
- 18 Join the side pieces together by drilling a pilot hole in each end of the long pieces and hammer in a larger nail to each corner to hold the edge pieces together. Using a nail punch, hammer these nails in just below the surface.



The spacer, cover and add-on.

- 19 Cut out the spacer piece. Disc sand the diagonal edge and then hand sand. With a layer of PVA glue and three nails join the spacer to the box as shown.
- 20 Cover all the nails with wood filler and let dry.
- 21 Disc sand all four sides of the box to make each surface is flat.
- 22 Mark out the cover and cut and disc sand it to fit perfectly.
- 23 Cut out the add-on piece and disc sand it to size.
- 24 Hand sand all edges and corners of all pieces, removing any ragged edges.
- 25 The lid needs to be able to slide under the cover and when it is painted it may become too thick to do this. So before painting thin the part of the lid that will slide under the cover by sanding it. Remember you only need to sand it down a paint thickness.



Painting

- 26 Put your name on all your pieces on places that won't be painted.
- 27 Paint the bottom sides and lip of the box black. Do not paint the insides or the spacer. (Painted surfaces don't glue as well).
- 28 Trace the add-on in the position it will be on the lid. Paint your chosen colour on the lid just covering the traced line. Also paint the sides and underside. Paint all surfaces at the same time even though you may get some on your fingers.
- 29 Paint the sides and top of your cover piece. (Don't paint the under side as painted surfaces don't glue well)
- 30 All painting takes about 10 minutes (on a clear day) to become touch dry.
- 31 Apply only a very thin smooth coat of paint using the tip of the brush.
- 32 Each piece (except the sides) will need two coats.



Assembly

- 33 Glue the add-on on to the lid and hold it together lightly for 15 min in a bench vice.
- 34 Mark out a dot for the hole for the screw as the pivot point for the lid. The dot should be half-way along the side and 5mm in.
- 35 Drill a pilot hole on the dot.
- 36 Screw in the wood screw with a Phillips head screwdriver.
- 37 Hold the cover in position and close the lid. The extra thickness of the paint can mean that the lid doesn't close properly. If this is the case then you will need to reduce the thickness of the overhanging part of the cover by hand sanding it on the underside.
- 38 When you are happy with the lid closing attach the cover with glue and nails.
- 39 Touch up the nails with a small amount of paint.
- 40 Leave to dry with the lid in the open position otherwise the pain will act like glue until it is perfectly dry.



Applying the pattern

- 41 Cut out your shapes from either white or black signwriter's vinyl. The squiggles need to be cut with scissors, but the stripes, lines and triangles are best cut with a scalpel and steel rule.
- 42 Peeling the back off each shape is quite fiddly
- 43 Be sure to space the pieces evenly on the shape
- 44 Make sure that the pattern 'bleeds' over the edge of the shape. The pattern needs to look like it continues past the edge of the piece.

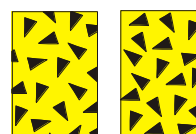

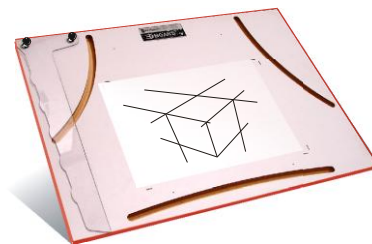

Accurate perspective drawing

Using a 3D board draw an exploded view of your Memphis pencease. Work in pencil first and then go over the lines you want to keep in fineliner. Use your finished pencease as reference.

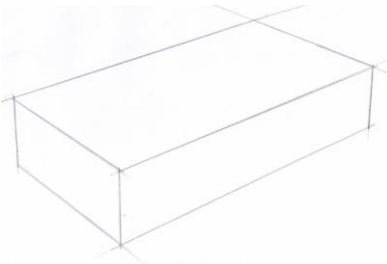

Here is a step by step example. Do these steps in pencil:

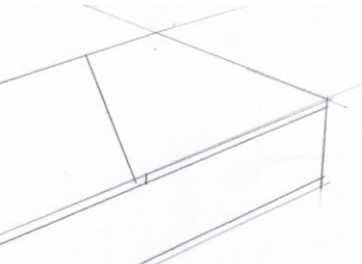
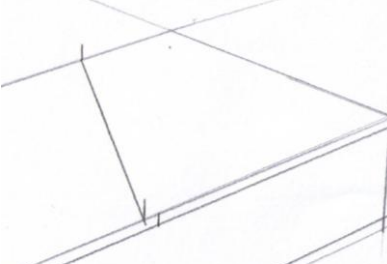
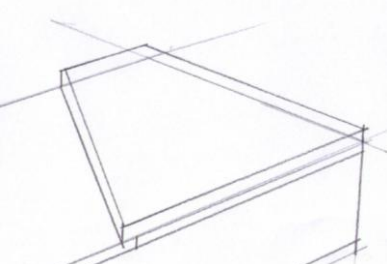
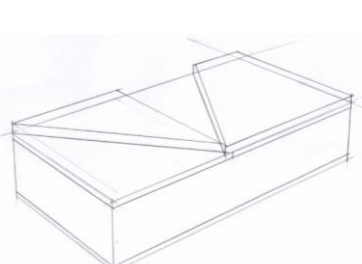
<p>1.</p>  <p>Begin by drawing a box of the right proportions (refer to your finished pencease)</p>	<p>2.</p>  <p>Add lines to indicate the lid, spacer and the base</p>	<p>3.</p>  <p>Draw the diagonal line showing the edge of the cover (take the tracking rule out of the slots for this line)</p>
<p>4.</p>  <p>Show the thickness of the cover by projecting small lines upwards</p>	<p>5.</p>  <p>Complete the top lines of the cover piece</p>	<p>6.</p>  <p>Draw the add on remembering to show thickness</p>

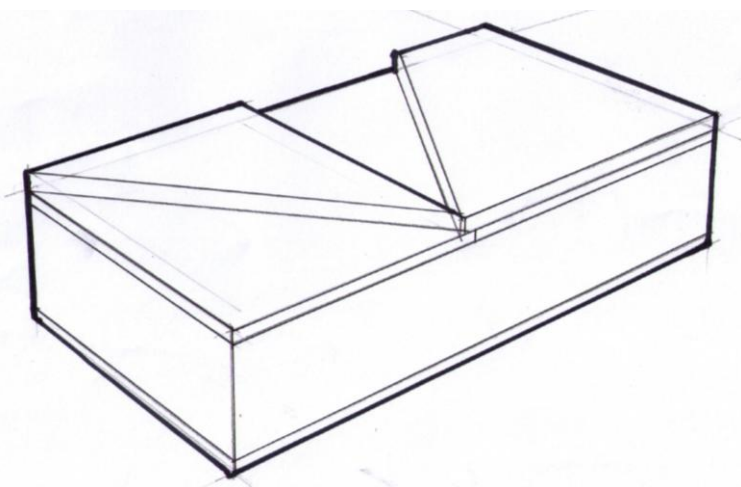

7.. Finish by going over the correct lines in fineliner.

Evaluation

During the design of your pencase, what were the main challenges you faced and how were these overcome?

Challenges	How you overcame them

If you were to design and make your pencase again what design would you do? Draw your ideas in the space below.

Class test: Memphis penceasemark /15

1. In which decade was the Memphis design style popular? (1 mark)

2. Memphis was a reaction to which design movement? (1 mark)

3. Who was the leader of the Memphis design group? (1 mark)

4. When an object reminds you of an animal, what style is this? (1 mark)

5. Are the following woods hardwood, softwood or manufactured boards: (5 marks)

Radiata pine

Cedar

Teak

Plywood

MDF

6. Name a piece of equipment that requires the use of hearing protection. (2 marks)

7. To mark out where a drill hole goes on a piece of wood what marking should you mark out on the wood? (1 mark)

8. True or False: A coping saw has a thin blade so it is easy to turn corners when cutting through a piece of wood. (1 mark)

9. When using the pedestal drill the table may be set too low for you to drill into the material required. What should you do? (2 marks)

Class test: Memphis pencease

mark /15

1. In which decade was the Memphis design style popular? (1 mark)

1980s

2. Memphis was a reaction to which design movement? (1 mark)

Modernism

3. Who was the leader of the Memphis design group? (1 mark)

Ettore Sottsass

4. When an object reminds you of an animal, what style is this? (1 mark)

Zoomorphism

5. Are the following woods hardwood, softwood or manufactured boards: (5 marks)

Radiata pine **Softwood**

Cedar **Softwood**

Teak **Hardwood**

Plywood **manufactured board**

MDF **manufactured board**

6. Name a piece of equipment that requires the use of hearing protection. (2 marks)

Disc sander

7. To mark out where a drill hole goes on a piece of wood what marking should you mark out on the wood? (1 mark)

A cross at the centre of the circle

8. True or False: A coping saw has a thin blade so it is easy to turn corners when cutting through a piece of wood. (1 mark)

True

9. When using the pedestal drill the table may be set too low for you to drill into the material required. What should you do? (2 marks)

Raise the table by unlocking, winding it up and then locking it.